

# Hygienic multi-stage centrifugal pump

FMS 125

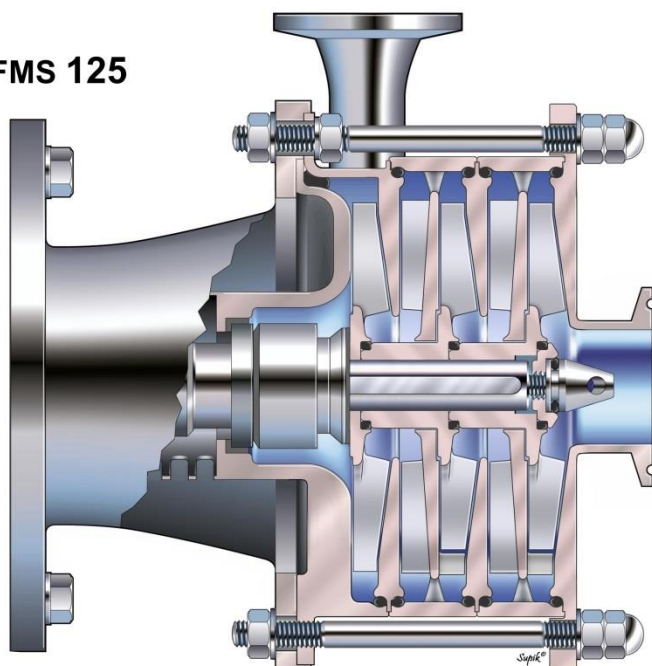

FMS 185



## FMS multi-stage pump

- Construction according to EHEDG guidelines.
- All wetted parts in contact in 1.4404/316L or duplex
- Investment cast pump casing and impeller
- Open impeller, so easy to clean during CIP
- **Very low NPSH and high efficiency**
- Surface finish: electropolished
- Mechanical seal according to EN 12756
- Motors according to IEC specifications
- Connections: DIN 11864, DIN 11851, SMS, Tri Clamp, RJT, etc.

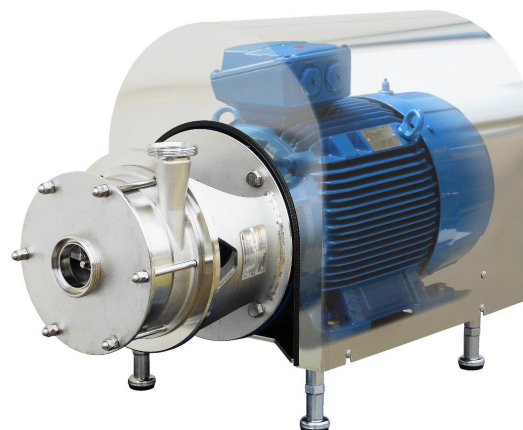

## Applications

For use in food, brew, beverage, pharmaceutical and chemical industries, as transfer and mixing pump for liquid food products, drinks, medicines, lotions, etc.

Typical applications: process pump for plate heat exchangers, pasteurizer systems, filters, filling machines, mixers, deaerators, carbonators and high pressure cleaning systems.

## Medium

Clean and slightly charged liquids with maximum viscosity of 250 cSt.

FMS /125 & 185

